



46815775
Edition 3
June 2012

Air Grinder

VT22 Series

Parts Information



Save These Instructions

 **Ingersoll Rand**

VT22 Series Air Grinder- Exploded View

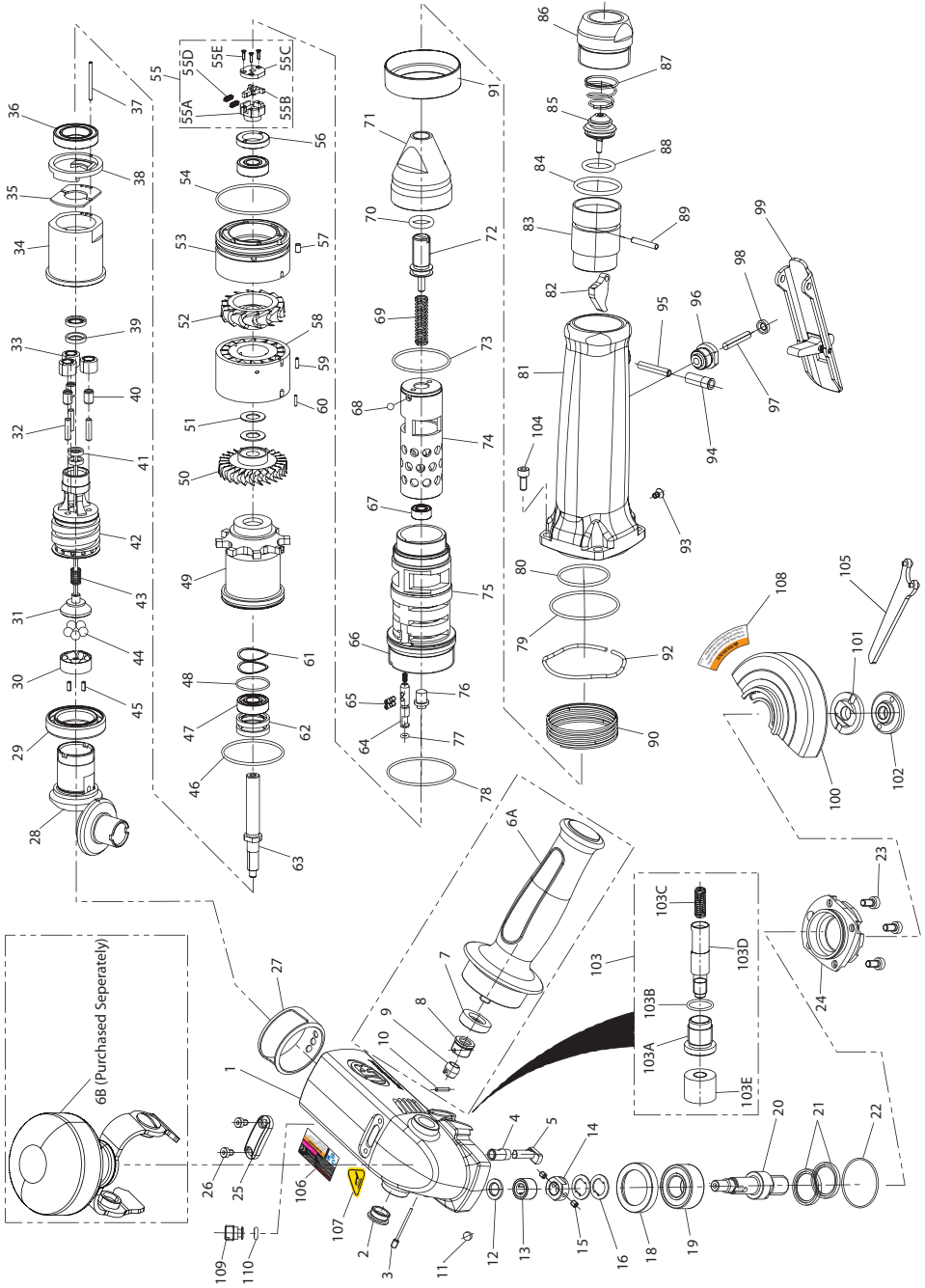

(Dwg. 17027962)

VT22 Series Air Grinder - Parts List

Item	Part Description	Part Number
	Angle Head Assembly	
1	Angle Housing	VT22-A40-P10
2	Blanking Plug	VT22-58-4
3	Spring Pin	VT22-667-1A
4	Spindle Lock Bush	VT22-667-7
5	Spindle Lock Pin	VT22-667-8
	Side Handel Assembly	
6A	AV Handle	VT22-A48
	Top Side Handel Assembly	
6B	Top AV Handle (Include item 7 (2), 8(2), 9(2), 10(2))	VT22-Top Handle
7	Spacer	VT22-58-1
8	Mount Bushing	VT22-58-2
9	Swivel Bush	VT22-58-3
10	Pin	VT22-120
11	Magnet	VT22-40-5
13	Needle Bearing	VT22-593-2
14	Clamp Nut	VT22-578
15	Grub Screw	VT22-55-6
16	Spring Washer	VT22-55-5A
18	Spacer Ring	VT22-55-4
19	Lower Arbor Bearing	VT22-593-1
20	Arbor	
	For models VT22-120P105 and VT22-120P1045	VT22-4-105
	For model VT-120P95M	VT22-4-95
21	Seal	VT22-55-2
22	O-Ring	VT22-55-3
23	Screw	VT22-55-8
24	Arbor Retaining Plate	VT22-55-1
25	Locator	VT22-EU-40-7
26	Screw	VT22-EU-40-6
27	Exhaust Deflector	VT22-40-8
	Gearbox Assembly	
28	Matched Gear Set	VT22-A552
29	Drive gear bearing	VT22-510-1
30	Speed Control Base	VT22-422-20
31	Speed Control Pin	VT22-422-23A
32	Gear Shaft(3)	VT22-501
33	Planetary Gear (3)	VT22-10
34	Gearbox Housing	VT22-406-1
35	Flow Plate	VT22-406-2
36	Rear Bearing	VT22-510-2
37	Motor Location Pin (1.5x20)	VT22-53-13
38	Rear Plate	VT22-406-3
39	Inner Seals (2)	VT22-8-2
41	Outer Seals (2)	VT22-8-3
42	Gear Support Housing	VT22-8-1
43	Spring	VT22-422-24
44	Speed Control Balls	VT22-422-22
45	Location Dowel	VT22-422-21
	Turbine Motor Assembly	

Item	Part Description	Part Number
46	Front Seal	VT22-53-10
47	Bearing (Pair)	VT22-53-12
48	Inner Seal	VT22-53-11
49	Exhaust Difuser	VT22-11
50	2nd Stage Impeller	VT22-53-2
51	Impellor Spring Washers	VT22-53-9
52	1st Stage Impeller	VT22-53-3
53	Inlet Flow Guide	VT22-12A
54	Rear Seal	VT22-53-8
55	E-Stop Assembly	
55A	Housing	VT22-422-1
55B	Piston	VT22-422-2
55C	Housing Cap	VT22-422-3
55D	Springs	VT22-422-4
55E	Screws	VT22-422-5
56	BRG Clamp Nut	VT22-53-4
57	Locating Dowel (3x5)	VT22-53-5
58	CTR Flow Guide	VT22-3A
59	Locating Dowel (2x6.3)	VT22-53-6
60	Locating Dowel (1.5x6.8)	VT22-53-7
61	BRG Spring Washers	VT22-53-14
62	Impellor Shaft Seals	VT22-53-15
63	Rotor Shaft	VT22-53-1
	Regulatory Assembly	
64	E-Stop Pin	VT22-422-6
65	Grub Screw (2)	VT22-422-14
66	Pin Spring	VT22-422-12
67	Bearing	VT22-422-13
68	Guide Ball	VT22-422-7
69	Spring	VT22-422-15
70	Adjuster Screw Seal	VT22-422-8
71	Speed Control Cap	VT22-422-18
72	Adjuster Screw	VT22-422-19
73	O-Ring	VT22-422-10
74	Speed Control Piston	VT22-422-17A
75	Speed Control Housing	VT22-422-16
76	Setting Sleeve	VT22-422-25/26
77	O-Ring	VT22-422-11
78	O-Ring	VT22-422-9
	Handle Assembly	
79	O-Ring	VT22-160-6
80	O-Ring	VT22-160-8
81	Main Handle	VT22-160-1
82	Throttle Cam	VT22-160-4
83	Sleeve	VT22-160-3
84	Inlet Seal	VT22-160-7
85	Throttle Valve	VT22-A302
86	Inlet Bushing	VT22-A465
87	Throttole Spring	VT22-51
88	O-Ring	VT22-160-5
89	Cam Pivot	VT22-A280
90	E-Stop Spring	VT22-422-27
91	E-Stop Ring	VT22-422-28

Item	Part Description	Part Number
92	Spring Ring	VT22-40-4
93	CSK Screw	VT22-160-10
94	Lever Pivot Bush	VT22-160-2
95	Lever Pivot	VT22-160-9
96	Throttle Pin Bush	VT22-160-11
97	Throttle Pin	VT22-161-1
98	Throttle Pin Seal	VT22-161-2
99	Lever Assembly	VT22-A400
	Guard Assembly (For Models VT22-120P105 and VT22-120P95M)	VT22-106-A5
100	Guard (5")	
108	Guard Warning Label	
	Guard Assembly (For Models VT22-120P1045)	VT22-106-A45
100	Guard (4.5")	
108	Guard Warning Label	
101	Wheel Flangex	
	For models VT22-120P105 and VT22-120P1045	VT22-337-5
	For model VT-120P95M	VT22-337-5M
102	Flange Nut	
	For models VT22-120P105 and VT22-120P1045	VT22-338-5
	For model VT-120P95M	VT22-338-5M
103	Spindle Lock Assembly	
103A	Spindle lock bush	VT22-667-2
103B	Seal	VT22-667-3
103C	Spring	VT22-667-4
103D	Plunger	VT22-667-5
103E	Spindle lock button	VT22-667-6
104	Housing screws (4)	VT22-40-1
105	Flange Nut Wrench	VT22-26M
106	Combo Label	
	For Model VT22-120P105	VT22-120P105-301
	For Model VT22-120P95M	VT22-120P95M-301
	For Model VT22-120P1045	VT22-120P1045-301
107	Heat Warning Label	VT22-99
108	Guard warning label	MG1-99G
109	Bleed Screw	VT22-40-2
110	O-ring	VT22-40-3

Parts and Maintenance

When the life of the tool has expired, it is recommended that the tool be disassembled, degreased and parts be separated by material so that they can be recycled.

Tool repair and maintenance should only be carried out by an authorized Service Center.

Refer all communications to the nearest **Ingersoll Rand** Office or Distributor.

Related Documentation

For additional information refer to:

Air Grinder Product Safety Information Manual 04584959.

Air Grinder Product Information Manual 46815767.

Manuals can be downloaded from www.ingersollrandproducts.com

www.ingersollrandproducts.com

© 2012 **Ingersoll-Rand** Company

